

# IOS Motor Systems

## SIZE 34 1.8° HYBRID IOS STEPPING MOTOR

Specifications	Holding Torque oz-in (N-cm) Series	Phase Current Amps		Number of Leads	Phase Resistance Ohms		Phase Inductance mH		Detent Torque oz-in (N-cm)	Rotor Inertia oz-in-sec <sup>2</sup> (kg-cm <sup>2</sup> ) Parallel	Length inches (cm)	Weight oz (gm)
		Series	Parallel		Series	Parallel	Series	Parallel				
M3-3424-IOS	265 (187.0)	3.0	6.0	8	1.8	0.5	5.6	1.4	20 (14.12)	0.190 (13.4)	3.325 (8.44)	72 (2016)

### TORQUE SPEED CURVES

Parallel: 6 Amps RMS, 80 VDC

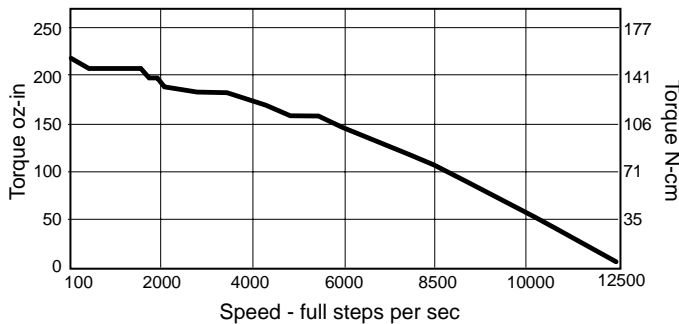

### CONNECTION

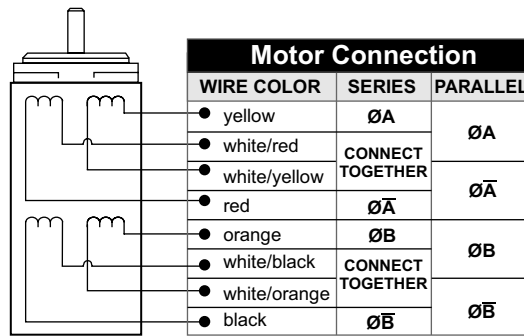

### OPTIONS

M3-3424-E(S) X\* ..... Motor w/Single Ended Encoder

M3-3424-E(D) X\* ..... Motor w/Differential Encoder

\* Replace X with encoder line count. Encoder kit available.

MRB0802 ..... 2 mm Pitch Ball Screw

MRB0812† ..... 12 mm Pitch Ball Screw

MRB1020 ..... 20 mm Pitch Ball Screw

MRB1402† ..... 2 mm Pitch Ball Screw

† Adapter plate required.

### MECHANICAL

Dimensions in Inches (mm)

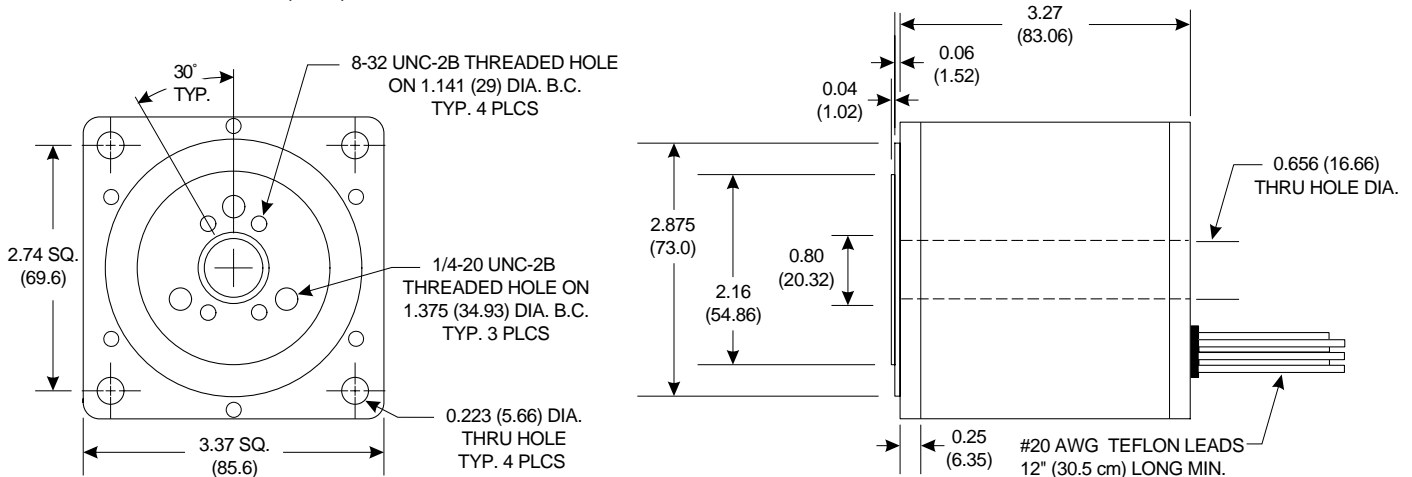

# IOS Motor Systems

## SIZE 34 1.8° HYBRID IOS STEPPING MOTOR

### FORCE SPEED CURVES

Parallel: 6 Amps RMS, 75 VDC

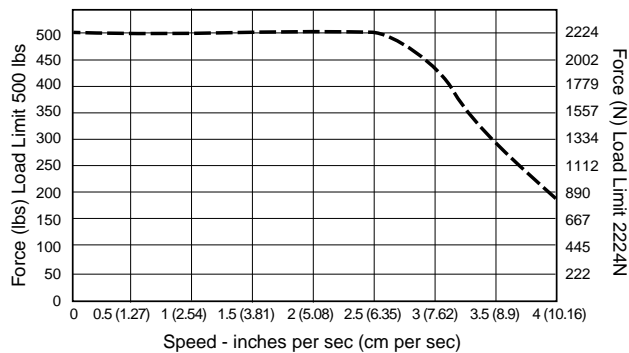

MRB0802 ..... 2 mm Pitch Ball Screw  
 Inches / (mm)  
 Travel/Full Step 0.000394 (0.005)  
 Max. Screw Deflection 0.0008 (0.020)  
 Backlash 0.002 (0.050)

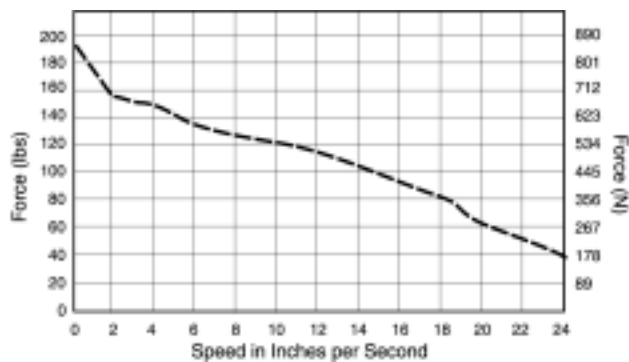

MRB0812 ..... 12 mm Pitch Ball Screw  
 Inches / (mm)  
 Travel/Full Step 0.00236 (0.005)  
 Max. Screw Deflection 0.0008 (0.020)  
 Backlash 0.002 (0.050)

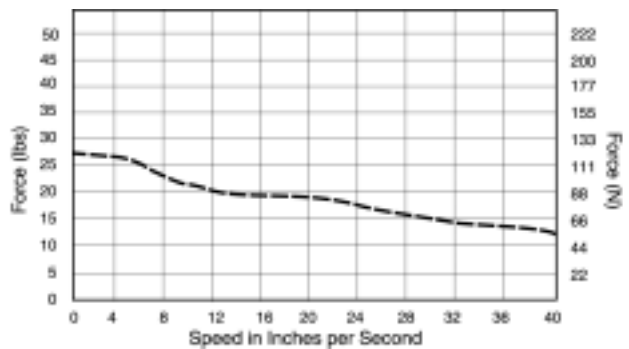

MRB1020 ..... 20 mm Pitch Ball Screw  
 Inches / (mm)  
 Travel/Full Step 0.00394 (0.005)  
 Max. Screw Deflection 0.0008 (0.020)  
 Backlash 0.002 (0.050)

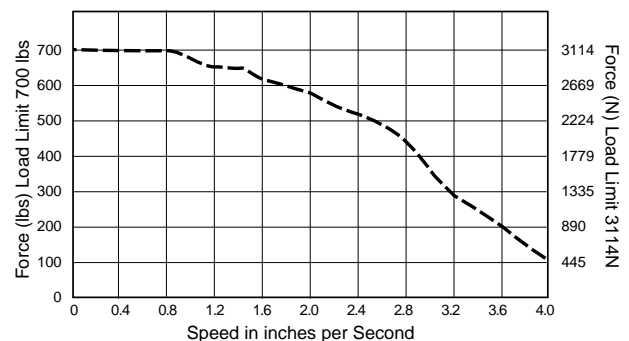

MRB1402 ..... 20 mm Pitch Ball Screw  
 Inches / (mm)  
 Travel/Full Step 0.000394 (0.005)  
 Max. Screw Deflection 0.0008 (0.020)  
 Backlash 0.002 (0.050)