

OMEGA SERIES DIGITAL PWM BRUSHLESS SERVO AMPLIFIERS SMA9815 AMPLIFIER MODEL NUMBERING

This section explains the model numbering system for Glentek's SMA9815 Omega Series Digital servo amplifier. The model numbering system is designed so that you, our customer, will be able to quickly and accurately create the model number for the amplifier that best suits your needs. In order to accurately select a complete part number, please follow the steps shown below:

- 1) Select the industry standard mounting configuration which meets your needs (i.e. 3U Plug-In, Module, Stand Alone or Multi-Axis).
- 2) Utilize the model number key in conjunction with the tables at the beginning of each section to select the complete model number for your requirements. Note: A complete model number example follows the model number key and includes a full description of the individual codes which make up the complete model number.

The following tables are used to fill in the different parts of the model number.
Refer to these when constructing a model number for your requirements.

<i>XXX</i>	<i>Power</i>	<i>Power Input Voltage</i>		<i>Continuous Current (Amps)</i>	<i>Peak Current (Amps)</i>
		<i>Module (VDC)</i>	<i>Stand Alone/Chassis (VAC)</i>		
000	Standard	190-370	208-240	15	30
001	High	190-370	208-240	20	40
002	Low	190-370	208-240	10	20
003	Standard	70-190	110-130	15	30
004	High	70-190	110-130	20	40
005	Low	70-190	110-130	10	20
006	Standard	30-70	Not Available	15	30
007	High	30-70	Not Available	20	40
008	Low	30-70	Not Available	10	20

<i>YYY</i>	<i>Logic Board Description</i>	<i>Connector</i>
000	Full Feature	DB9
001*	Full Feature	RJ45
002	Reduced Wire Encoder (Sanyo Denki and Tamagawa)	DB9
003*	Reduced Wire Encoder (Sanyo Denki and Tamagawa)	RJ45
004	Yaskawa Encoder	DB9
005*	Yaskawa Encoder	RJ45
006	Pulse Follower	DB9
007*	Pulse Follower	RJ45
008	2 phase Current Mode	DB9
009*	2 phase Current Mode	RJ45

*Not available in 3U Plug-In Amplifier

<i>MM</i>	<i>Mounting</i>
<i>omit</i>	1-axis module
1A	1-axis Stand Alone
2A	2-axis Chassis
4A	4-axis Chassis

<i>N</i>	<i>Number of amps installed</i>
1	One amplifier installed
2	Two amplifiers installed
3	Three amplifiers installed
4	Four amplifiers installed

<i>F</i>	<i>Fan Power</i>
1	110VAC
2	220VAC

OMEGA SERIES DIGITAL PWM BRUSHLESS SERVO AMPLIFIERS SMA9815 MODEL NUMBERING KEY

SMA9815-3U Plug-In Amplifier

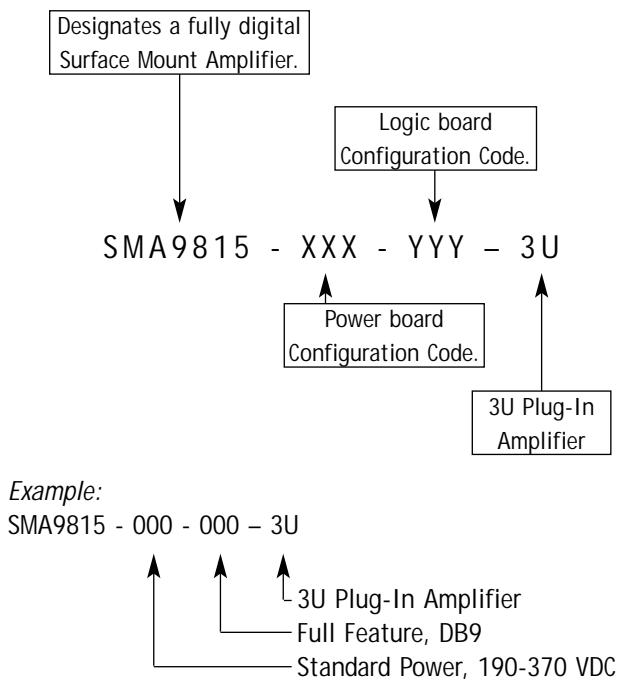

SMA9815 Amplifier Module

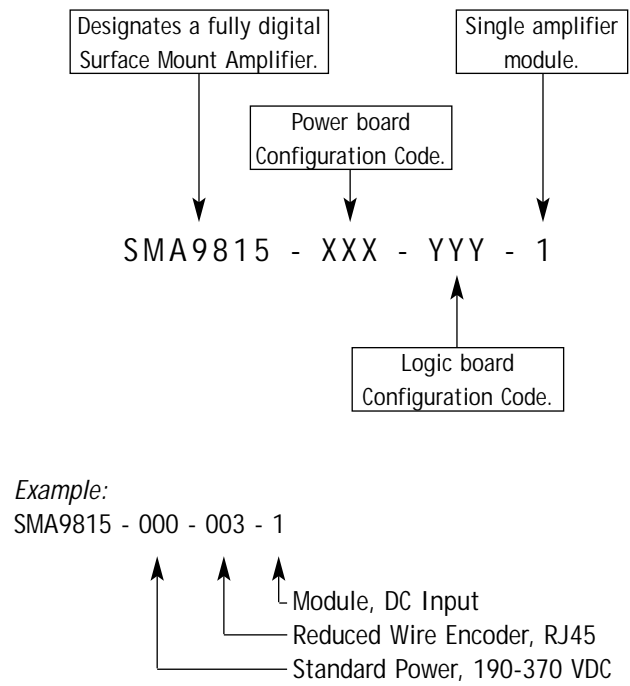

SMA9815 Stand Alone Amplifier

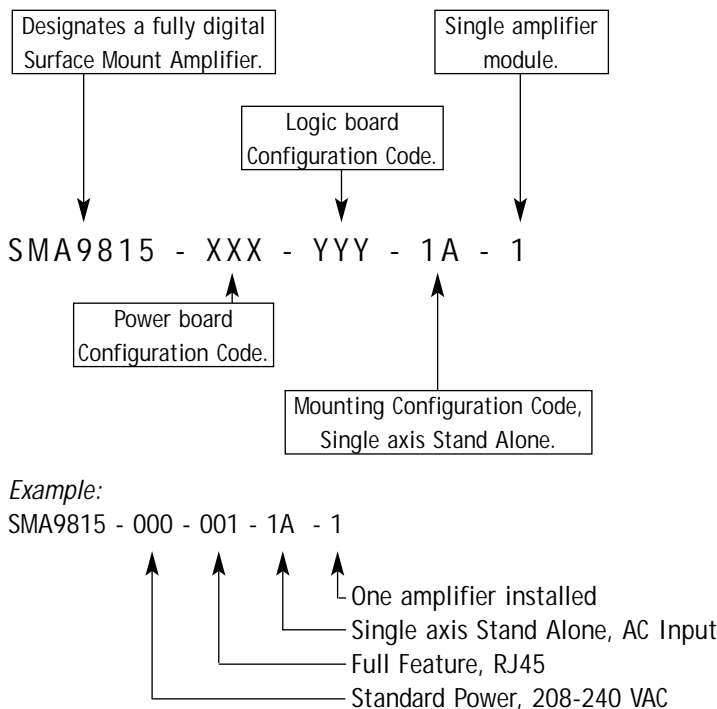

SMA9815 Multi-Axis Amplifier

