

# BRUSHLESS SERVO MOTORS GMBM80 SERIES WITH BRAKE MECHANICAL DIMENSIONS

## GMBM80 SERIES WITH BRAKE

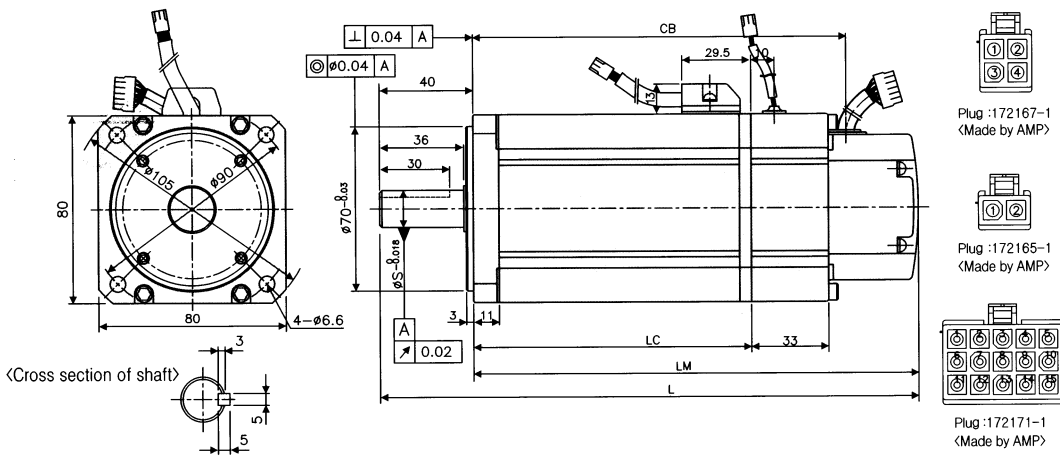

Pin #	Phase
1	T
2	S
3	R
4	Ground

(Motor Power Connector)

Pin #	Color	Phase
1	Red	+
2	White	-

(Brake Connector)

Pin#	Phase	Pin#	Phase
1	A+	9	HALL 2+
2	A-	10	HALL 2-
3	B+	11	HALL 1+
4	B-	12	HALL 1-
5	Z+	13	+5V
6	Z-	14	COMMON
7	HALL 3+	15	SHIELD
8	HALL 3-		

(Encoder Feedback Connector)

External Dimension						
Model Number	L	LM	LC	S	Weight (kg)	
GMBM80400-29, GMBM80300-34	191	151	79	14	2.45	
GMBM80600-35, GMBM80500-43	211	171	99	16	3.09	
GMBM80800-36, GMBM80550-45	231	191	119	16	3.75	
GMBM801000-39, GMBM80650-46	251	211	139	16	4.40	

Glentek, Inc.

208 Standard Street • El Segundo, California 90245 USA  
(310) 322-3026 • (310) 322-7709 Fax • www.glentek.com