

# BRUSHLESS SERVO MOTORS GMBM180 SERIES WITH BRAKE MECHANICAL DIMENSIONS

## GMBM180 SERIES WITH BRAKE

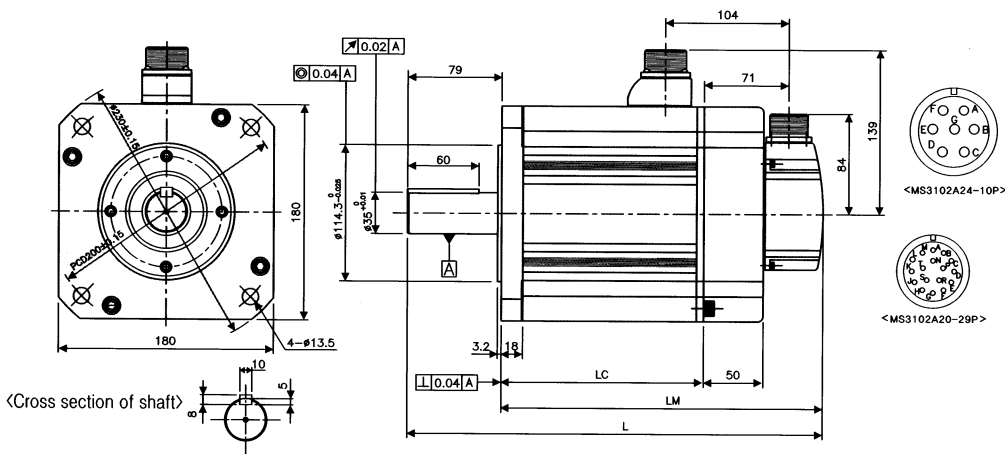

Pin #	Phase
A	T
B	S
C	R
D	Ground
E	+
F	-

(Motor Power Connector)

External Dimension				
Model Number	L	LM	LC	Weight (kg)
GMBM1803000-37, GMBM1802200-50	311.8	232.8	132.8	17.6
GMBM1801800-80, GMBM1801200-79	344.8	265.8	165.8	24.9
GMBM1805000-36, GMBM1803500-56	394.8	315.8	215.8	33.5
GMBM1802900-56, GMBM1802000-81	394.8	315.8	215.8	33.5
GMBM1805500-56, GMBM1804400-56	454.8	375.8	275.8	42.8
GMBM1803000-85				
GMBM1807500-66, GMBM1804400-84				

Pin#	Phase	Pin#	Phase
A	A+	M	HALL 2+
B	A-	N	HALL 2-
C	B+	P	HALL 1+
D	B-	R	HALL 1-
E	Z+	H	+5V
F	Z-	G	COMMON
K	HALL 3+	J	SHIELD
L	HALL 3-		

(Encoder Feedback Connector)