

BRUSHLESS SERVO MOTORS

GMB5600 SERIES MECHANICAL DIMENSIONS

	DIM. "A" - INCH [mm]
GMB5627	11.31 [287.3mm]
GMB5654	14.01 [355.9mm]
GMB5681	16.71 [424.4mm]
GMB56108	19.41 [493.0mm]

MECHANICAL NOTES:

1. AXIAL LOAD: 50 LBS. [23 kg.] MAX.
2. RADIAL LOAD: 150 LBS. [68 kg.] MAX.
@ 1" [25mm] FROM FACE.
3. BRAKE MOTOR= DIM. "A" + 2.75 [70mm]

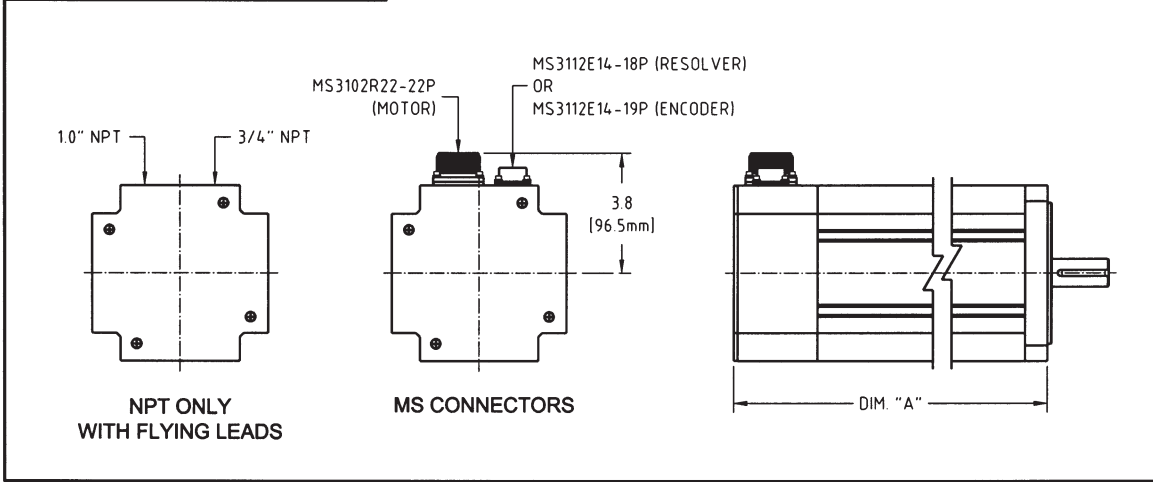

ENGLISH MOTOR

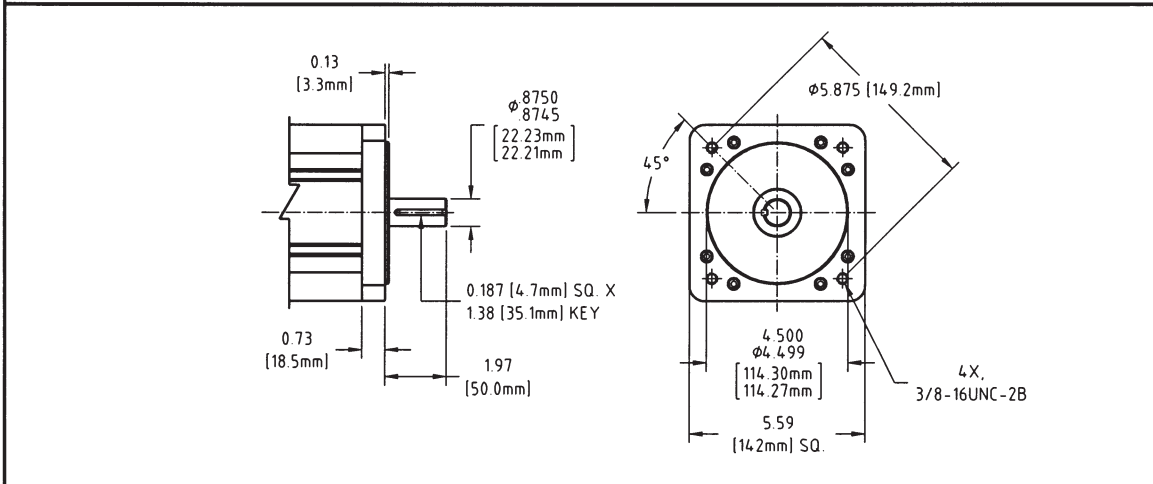

METRIC MOTOR

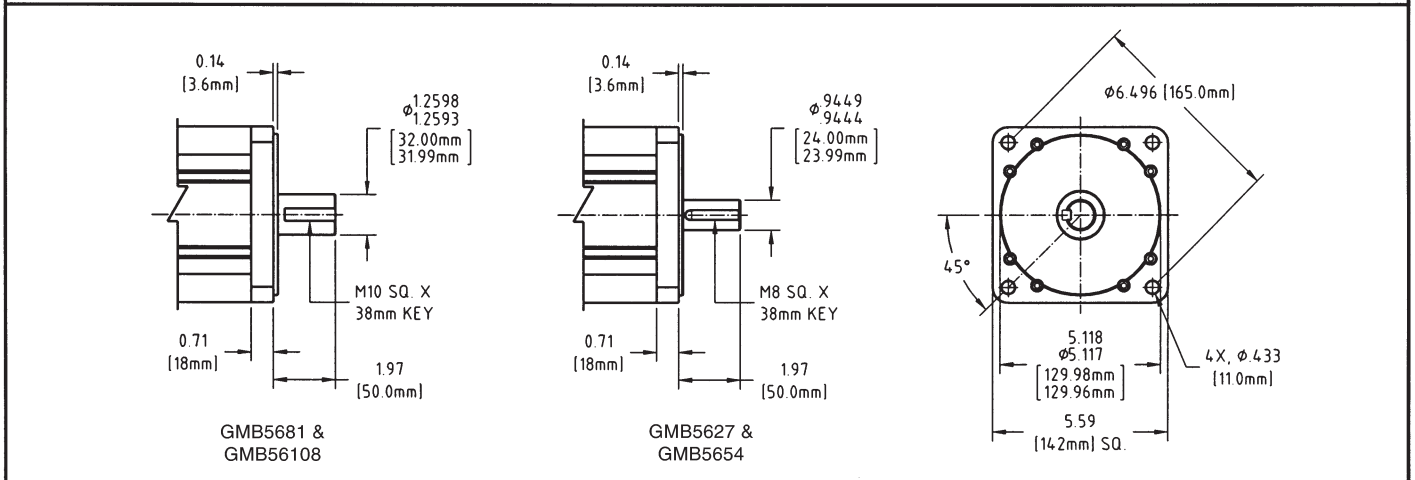

Glentek, Inc.

208 Standard Street • El Segundo, California 90245 USA
(310) 322-3026 • (310) 322-7709 Fax • www.glentek.com