

BRUSHLESS SERVO MOTORS

GMB3500 SERIES MECHANICAL DIMENSIONS

	DIM. "A" - INCH [mm]
GMB3515	5.00 [127.0mm]
GMB3530	6.55 [166.4mm]
GMB3545	8.09 [205.5mm]

MECHANICAL NOTES:

1. AXIAL LOAD: 25 LBS. [11 kg.] MAX.
2. RADIAL LOAD: 40 LBS. [18 kg.] MAX.
@ 1" [25mm] FROM FACE.
3. BRAKE MOTOR= DIM. "A" + 1.50 [38mm]

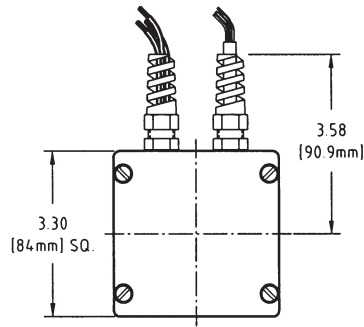

LIQUID TIGHT STRAIN RELIEF WITH FLYING LEADS

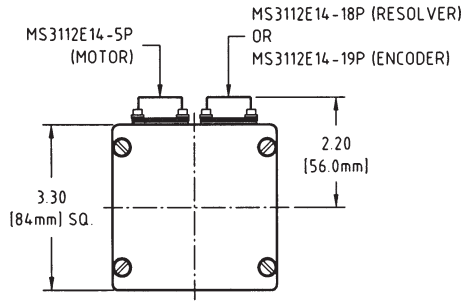

OPTIONAL MS CONNECTOR CONFIGURATION

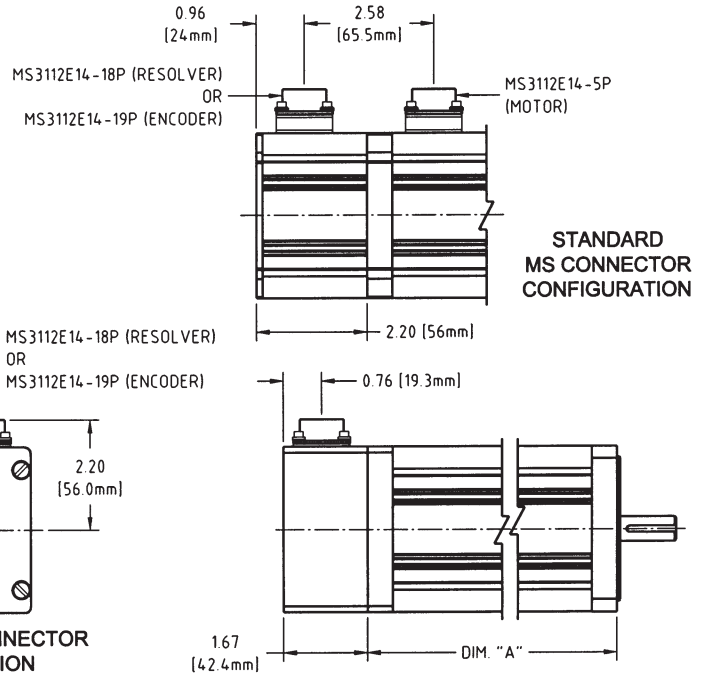

STANDARD MS CONNECTOR CONFIGURATION

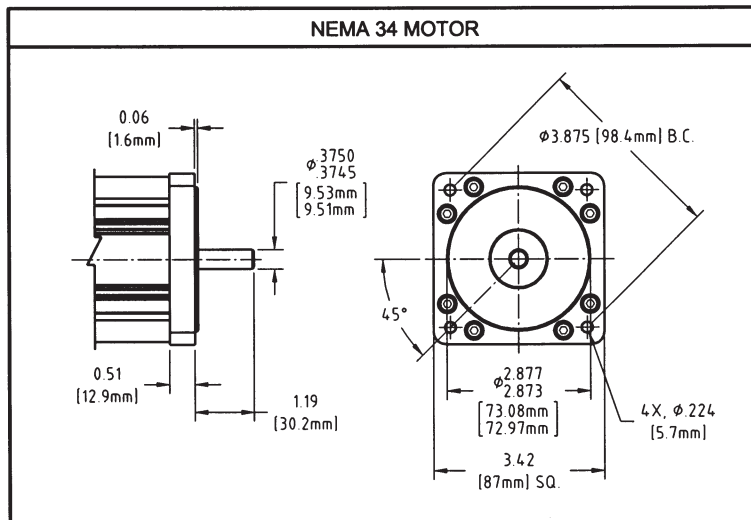
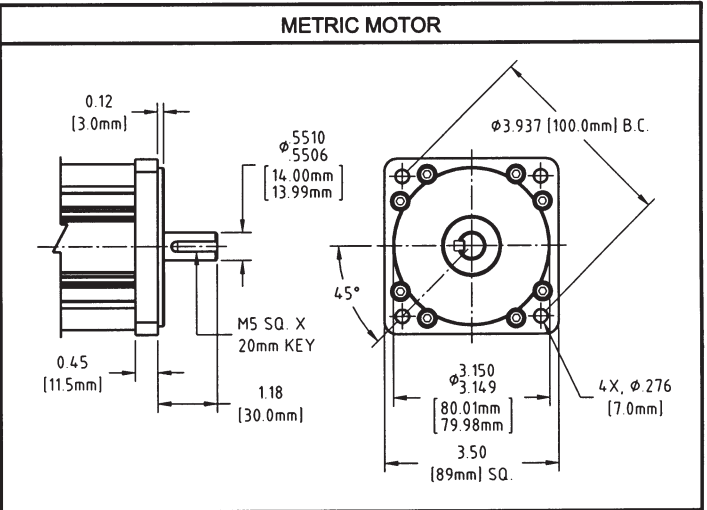
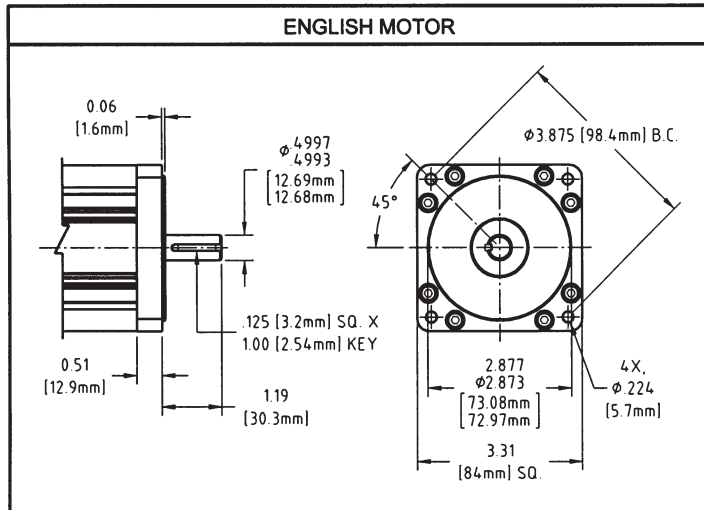

Glentek, Inc.

208 Standard Street • El Segundo, California 90245 USA
(310) 322-3026 • (310) 322-7709 Fax • www.glentek.com